



Accessories for Sunny Island

## **MULTICLUSTER BOX FOR**

## **SUNNY ISLAND 4548-US / 5048-US / 6048-US**

**Installation Manual**

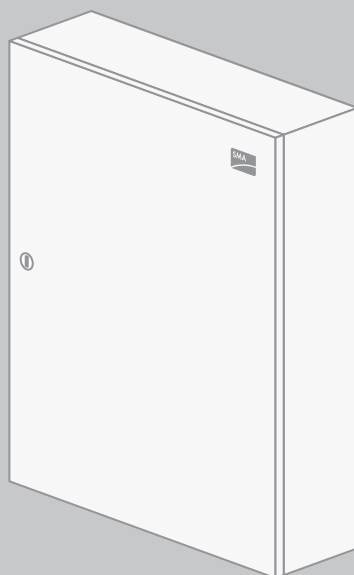



Copyright © 2012 SMA America, LLC. All rights reserved.

No part of this document may be reproduced, stored in a retrieval system, or transmitted, in any form or by any means, electronic, mechanical, photographic, magnetic or otherwise, without the prior written permission of SMA America, LLC.

SMA America, LLC doesn't make representations, express or implied, with respect to this documentation or any of the equipment and/or software it may describe, including (with no limitation) any implied warranties of utility, merchantability, or fitness for any particular purpose. All such warranties are expressly disclaimed. Neither SMA America, LLC nor its distributors or dealers shall be liable for any indirect, incidental, or consequential damages under any circumstances.

(The exclusion of implied warranties may not apply in all cases under some statutes, and thus the above exclusion may not apply.)

Specifications are subject to change without notice. Every attempt has been made to make this document complete, accurate and up-to-date. Readers are cautioned, however, that SMA America, LLC reserves the right to make changes without notice and shall not be responsible for any damages, including indirect, incidental or consequential damages, caused by reliance on the material presented, including, but not limited to, omissions, typographical errors, arithmetical errors or listing errors in the content material.

All trademarks are recognized even if these are not marked separately. Missing designations do not mean that a product or brand is not a registered trademark.

SMA America, LLC  
3801 N. Havana Street  
Denver, CO 80239 U.S.A.

## IMPORTANT SAFETY INSTRUCTIONS

### SAVE THESE INSTRUCTIONS

This manual contains important instructions for the following products:

- Multicenter Box 12-US (MCB-12U)

This manual must be followed during installation and maintenance.

The product is designed and tested according to international safety requirements, but as with all electrical and electronic equipment, certain precautions must be observed when installing and/or operating the product. To reduce the risk of personal injury and to ensure the safe installation and operation of the product, you must carefully read and follow all instructions, cautions and warnings in this manual.

### Warnings in this document

A warning describes a hazard to equipment or personnel. It calls attention to a procedure or practice, which, if not correctly performed or adhered to, could result in damage to or destruction of part or all of the SMA equipment and/or other equipment connected to the SMA equipment or personal injury.

#### **DANGER**

DANGER indicates a hazardous situation which, if not avoided, will result in death or serious injury.

#### **WARNING**

WARNING indicates a hazardous situation which, if not avoided, could result in death or serious injury.

#### **CAUTION**





CAUTION indicates a hazardous situation which, if not avoided, could result in minor or moderate injury.

#### **NOTICE**

NOTICE is used to address practices not related to personal injury.

## Other Symbols in this document

In addition to the safety and hazard symbols described on the previous pages, the following symbol is also used in this manual:

Symbol	Erklärung
	This symbol accompanies notes that call attention to supplementary information that you must know and use to ensure optimal operation of the system.
	Indicates a requirement for meeting a specific goal.
	Desired result
	A problem that could occur

## Markings on this product

The following symbols are used as product markings with the following meanings.



### Warning regarding dangerous voltage

The product works with high voltages. All work on the product must only be performed as described in the documentation of the product.



### Beware of hot surface

The product can become hot during operation. Do not touch the product during operation.



### Observe the operating instructions

Read the documentation of the product before working on it. Follow all safety precautions and instructions as described in the documentation.



UL508A es el estándar que Underwriters Laboratories aplica a estos productos para certificar que cumple con los requisitos el IEEE 1547 y el IEEE 1547.1. IEEE 929-2000 proporciona recomendaciones con respecto al equipamiento apropiado y la funcionalidad necesaria para asegurar un funcionamiento compatible cuando la generación de potencia está conectada a la red de la empresa de servicio.

## General Warnings

### **⚠ WARNING**

#### General Warnings

All electrical installations must be done in accordance with the local and National Electrical Code<sup>®</sup> ANSI/NFPA 70 or the Canadian Electrical Code<sup>®</sup> CSA C22.1. This document does not and is not intended to replace any local, state, provincial, federal or national laws, regulation or codes applicable to the installation and use of the product, including without limitation applicable electrical safety codes. All installations must conform with the laws, regulations, codes and standards applicable in the jurisdiction of installation. SMA assumes no responsibility for the compliance or noncompliance with such laws or codes in connection with the installation of the product.

The product contains no user-serviceable parts.

Before installing or using the product, read all of the instructions, cautions, and warnings in this manual.

Before connecting the product to the electrical utility grid, contact the local utility company. This connection must be made only by qualified personnel.

Wiring of the product must be made by qualified personnel only.

# Table of Contents

<b>1</b>	<b>Information on this Manual</b> .....	<b>9</b>
<b>2</b>	<b>Safety</b> .....	<b>11</b>
2.1	Intended Use .....	11
2.2	Necessary Skills for Electrically Qualified Persons .....	12
2.3	Safety Precautions .....	13
<b>3</b>	<b>Scope of Delivery</b> .....	<b>14</b>
<b>4</b>	<b>Product Description</b> .....	<b>16</b>
4.1	Multicenter Box for Sunny Island 4548-US / 5048-US / 6048-US .....	16
4.2	Switching Mechanism of the Multicenter Box .....	17
4.3	Communication Interface .....	17
4.4	Cluster Principle when Forming the Stand-Alone Grid .....	18
4.5	Type Label .....	18
<b>5</b>	<b>Installation</b> .....	<b>19</b>
5.1	Selecting the Installation Location .....	19
5.2	Transporting the Multicenter Box .....	23
5.3	Installing the Multicenter Box .....	24
5.4	Mounting the Multicenter Box .....	27
<b>6</b>	<b>Electrical Connection</b> .....	<b>29</b>
6.1	Safety during Electrical Connection .....	29
6.2	Overview of the Connection Area .....	30
6.3	Inserting the Cables .....	32
6.4	Leading out the Cables .....	34
6.5	Connecting the Generator .....	35
6.6	Connecting Loads .....	37

6.7	Connecting the PV Plant . . . . .	40
6.8	Connecting the Off-Grid Inverter . . . . .	43
6.9	Grounding the Multicluster System . . . . .	45
6.10	Connecting the Control and Measuring Cables . . . . .	46
6.11	Connecting the Communication Cable . . . . .	47
<b>7</b>	<b>Commissioning . . . . .</b>	<b>48</b>
<b>8</b>	<b>Opening and Closing the Multicluster Box . . . . .</b>	<b>50</b>
<b>9</b>	<b>Disconnecting the Device from Voltage Sources . . . . .</b>	<b>52</b>
<b>10</b>	<b>Maintenance . . . . .</b>	<b>53</b>
<b>11</b>	<b>Replacing Thermal Fuses . . . . .</b>	<b>54</b>
<b>12</b>	<b>Decommissioning . . . . .</b>	<b>56</b>
12.1	Dismantling the Multicluster Box . . . . .	56
12.2	Storing the Multicluster Box . . . . .	56
12.3	Disposing of the Multicluster Box . . . . .	56
<b>13</b>	<b>Technical Data . . . . .</b>	<b>57</b>
<b>14</b>	<b>Contact . . . . .</b>	<b>61</b>



# 1 Information on this Manual

## Validity

This manual is valid for the device type MCB-12U.

## Target Audience

This manual is intended for electrically qualified persons. Only qualified personnel are allowed to perform the tasks set forth in this manual (see Section 2.2 "Necessary Skills for Electrically Qualified Persons", page 12).

## Additional Information

Additional information is available at [www.SMA-America.com](http://www.SMA-America.com):

Document title	Document type
PV inverters – Use of PV inverters in off-grid and backup systems in the US, Canada and Puerto Rico	Technical information

## Typography

Typography	Usage	Example
"light"	<ul style="list-style-type: none"> <li>• Connections</li> <li>• Slots</li> </ul>	<ul style="list-style-type: none"> <li>• Insert the conductor into the "Master ComSyncln" jack.</li> </ul>
<b>bold</b>	<ul style="list-style-type: none"> <li>• Elements to be selected</li> </ul>	<ul style="list-style-type: none"> <li>• Set the switch lever on the "CB5" fuse-switch-disconnector to <b>ON</b>.</li> </ul>

## Nomenclature

The following nomenclature is used in this manual:

Complete designation	Designation in this manual
SMA Solar Technology America, LLC	SMA
Multicluster Box for Sunny Island 4548-US/5048-US/6048-US	Multicluster Box
Sunny Island 4548-US/5048-US/6048-US	Off-grid inverter
AC sub-distribution for the connected loads	Loads

<b>Abbreviation</b>	<b>Designation</b>	<b>Explanation</b>
AC	Alternating Current	-
DC	Direct Current	-
MSL	Mean Sea Level	-
PE	Protective Earth	Protective conductor
PV	Photovoltaics	-

## 2 Safety

### 2.1 Intended Use

The Multicluseter Box for Sunny Island 4548-US / 5048-US / 6048-US is the AC main distribution that allows the formation of a 3-phase stand-alone grid with up to 12 off-grid inverters.

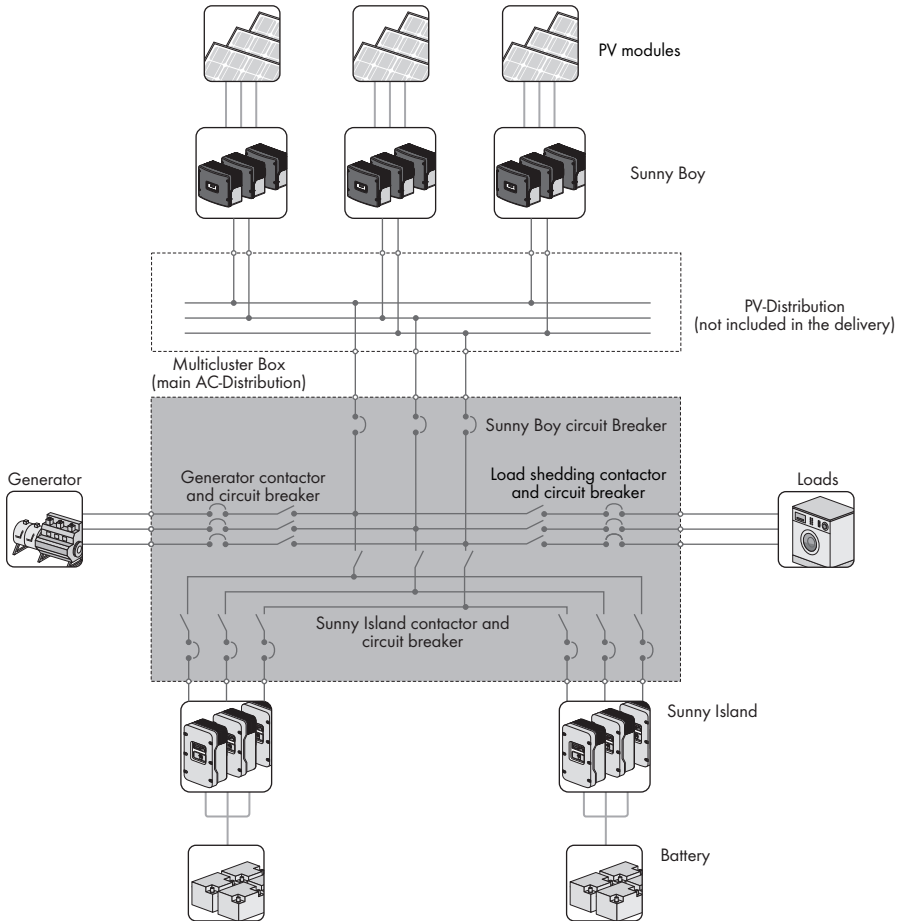

Figure 1: Principle of a multicluseter system with Multicluseter Box

**Mounting requirements:**

The Multicluster Box is designed for use at altitudes of up to 6 560 ft. (2 000 m) above mean sea level. If you would like to use the Multicluster Box at elevations above 6 560 ft. (2 000 m), contact the SMA Service Line (see Section 14 "Contact", page 61).

The Multicluster Box is suitable for indoor use only.

- Do not mount the Multicluster Box on flammable construction materials.
- Do not mount the Multicluster Box near highly flammable materials.
- Do not mount the Multicluster Box in potentially explosive atmospheres.

**Electrical connection requirements:**

You may only operate the Multicluster Box with the following off-grid inverters:

- Sunny Island 4548-US
- Sunny Island 5048-US
- Sunny Island 6048-US

Only the off-grid inverters, loads, the generator and one additional power generator such as a PV plant or small wind turbine system may be connected to the Multicluster Box.

The Multicluster Box's connections to the PV plant, generator and loads must not exceed a maximum AC power of 108 kW at 77°F (25°C).

The Multicluster Box must not be connected to the power distribution grid.

**General terms of use:**

Only use the Multicluster Box in accordance with the information provided in the documentation. Any other use can result in personal injury or property damage.

The documentation is an integral part of this product.

- Read and follow the documentation for the proper and optimum use of the Multicluster Box.
- Keep the documentation in a convenient place for future reference.

Do not use the Multicluster Box in case of technical defects. Unauthorized installations and modifications will void both the operation permission and all warranty claims.

## 2.2 Necessary Skills for Electrically Qualified Persons

The tasks described in this manual may only be performed by electrically qualified persons.

Electrically qualified persons must have the following skills:

- Knowledge of how the multicluster system works and is operated
- Training in how to deal with the dangers and risks associated with installing and using electrical devices
- Training in the installation and commissioning of electrical devices
- Knowledge of all applicable standards and guidelines
- Knowledge of and adherence to this manual and all safety precautions

## 2.3 Safety Precautions

### DANGER

#### **Danger to life through electric shock**

High voltages in live component parts.

Risk of death or serious injury from touching component parts.

- Disconnect the multicluster system from all voltage sources before carrying out any work on the Multicluster Box (see Section 9 "Disconnecting the Device from Voltage Sources", page 52).

### CAUTION

#### **Risk of burns due to hot terminals**

The terminals inside the Multicluster Box will become hot during operation.

- Do not touch the terminals during operation.
- Allow the terminals to cool down after decommissioning.

### NOTICE

#### **Humidity and dust intrusion**

Possible damage to the Multicluster Box.

- Protect the Multicluster Box from dust and water whenever it is open.
- Close the door of the Multicluster Box after all work is complete.

#### **Electrostatic discharge upon contact**

Possible damage to the electronic component parts of the Multicluster Box.

- Ground yourself before touching any component parts.

### 3 Scope of Delivery

Check the delivery for completeness and any visible external damage. Contact your specialty retailer if the delivery is incomplete or you find any damage.

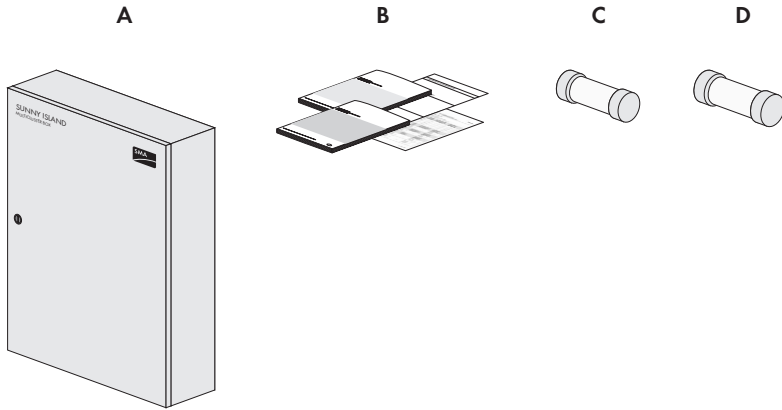

Figure 2: Components included in delivery

Position	Quantity	Description
A	1	Multicluster Box
B	1	Installation manual
C	2	Spare fuse 2 A
D	2	Spare fuse 6 A

### Multicluster Piggy-Back\*

The number of Multicluster Piggy-Backs, RJ45 cables and terminators included in the delivery depends on your order specifications.

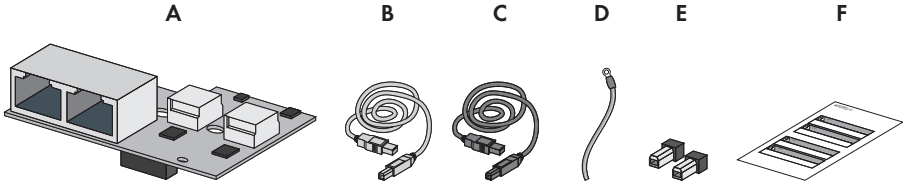

Figure 3: Parts of the Multicluster Piggy-Back

Position	Quantity	Description
A	2 ... 4	Multicluster Piggy-Back
B	2 ... 4	RJ45 cable: 16 ft. (5 m), yellow
C	2 ... 4	RJ45 cable: 16 ft. (5 m), gray
D	2 ... 4	Grounding cable
E	4 ... 8	Terminator
F	1	Technical description

\*optional

## 4 Product Description

### 4.1 Multicluster Box for Sunny Island 4548-US / 5048-US / 6048-US

The Multicluster Box for Sunny Island 4548-US / 5048-US / 6048-US is the AC main distribution that allows the formation of a 3-phase stand-alone grid with up to 12 off-grid inverters.

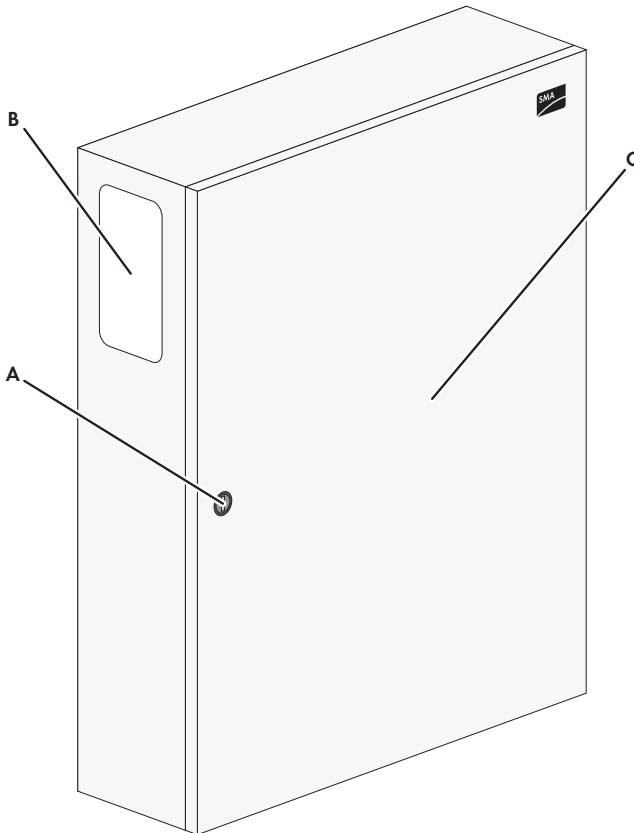

Figure 4: Design of the Multicluster Box

Position	Designation
A	Door locking mechanism
B	Door
C	Type label



A 3-phase stand-alone grid that relies on the cluster principle with up to 12 off-grid inverters is capable of switching to higher power levels and adapting to the power requirements of the connected loads. In such a grid configuration, the Multicluster Box acts as the AC main distribution by making the following elements available:

- Connections for all the necessary components in an off-grid system
- Internal circuitry for these connections
- Required switching mechanism for the load management of stand-alone grids

To enable control of this switching mechanism, the Multicluster Box is connected to the communication bus of the main cluster.

## 4.2 Switching Mechanism of the Multicluster Box

The switching mechanism of the Multicluster Box is composed of fuse-switch-disconnectors and contactors.

### **Fuse-switch-disconnector:**

The 3 fuse-switch-disconnectors allow you to manually connect or disconnect the generator, PV plant, and loads. Manual connection or disconnection is necessary, for example, when commissioning the system or for maintenance purposes.

### **Contactors:**

The contactors inside the Multicluster Box have various tasks.

- Generator contactor
 

The generator contactor is designed to turn on grid-forming generators. These generators supply power to an existing grid at a fixed voltage and fixed frequency. This allows the stand-alone grid to adjust to the prescribed grid parameters. Once the voltage and frequency of the stand-alone grid match the specifications prescribed by the generator, the generator contactor will establish a connection.
- Load-shedding contactor
 

The load-shedding contactor disconnects the loads from the stand-alone grid whenever the batteries fall below a specified minimum charge. This protects the batteries from damage due to deep discharge.

## 4.3 Communication Interface

The SIBUCTRL main control circuit board is the communication interface of the Multicluster Box. This control circuit board is connected to the communication bus of the main cluster via an RJ45 cable. This connection allows the master of the main cluster to forward commands to the 2 slaves and to receive confirmation regarding the implementation of those commands.

The 3 control and measuring cables and the communication cable of the Multicluster Box are connected to the SIBUCTRL.

### 4.4 Cluster Principle when Forming the Stand-Alone Grid

In a stand-alone grid, a set of 3 off-grid inverters can form a cluster and thus provide a 3-phase grid. 1 off-grid inverter functions as the master while the other 2 are slaves.

A maximum of 4 clusters can form a shared stand-alone grid (multicuster system). The leading cluster is the main cluster. The other clusters function as extension clusters. The master of the main cluster controls and monitors the entire stand-alone grid.

### 4.5 Type Label

The type label clearly identifies the Multicuster Box. The type label is located externally on the left side of the Multicuster Box enclosure.

A second type label can also be found on the upper right of the Multicuster Box.

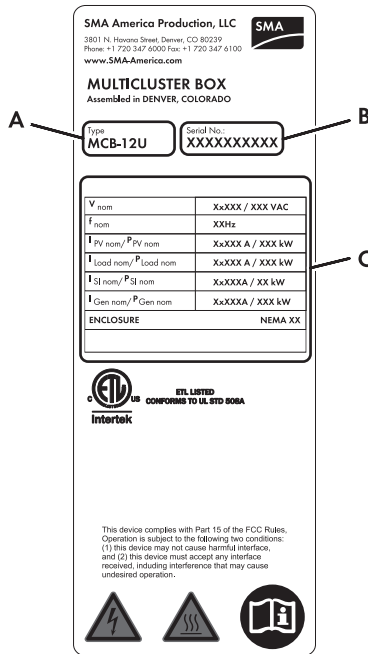

Figure 5: Layout of the type label

Position	Designation	Explanation
A	Model Type	Device type
B	Serial Number	Serial number of Multicuster Box
C	Device-specific characteristics	-

## 5 Installation

### 5.1 Selecting the Installation Location

Installation location requirements:

#### **⚠ WARNING**

##### **Danger to life due to fire or explosions**

With electrical devices, there is always a certain danger that a fire may break out.

- Do not mount the Multiclusture Box on flammable construction materials.
- Do not mount the Multiclusture Box near highly flammable materials.
- Do not mount the Multiclusture Box in potentially explosive atmospheres.

- The installation foundation must be stable and capable of bearing the weight of the Multiclusture Box, which is 400 lbs. (180 kg). A concrete foundation would suffice, for example.
- The wall for attaching the Multiclusture Box must be stable and capable of bearing the weight of the Multiclusture Box, which is 400 lbs (180 kg). In this respect, a solid brick wall would suffice, for example.
- The installation location must be safely accessible at all times.

**Observe the dimensions of the Multiclusture Box:**

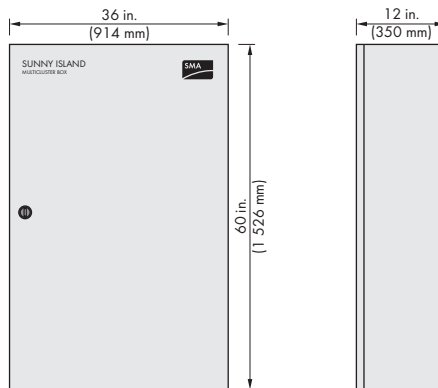

Figure 6: Dimensions of the Multiclusture Box

**Observe the minimum passage width and minimum clearances:**

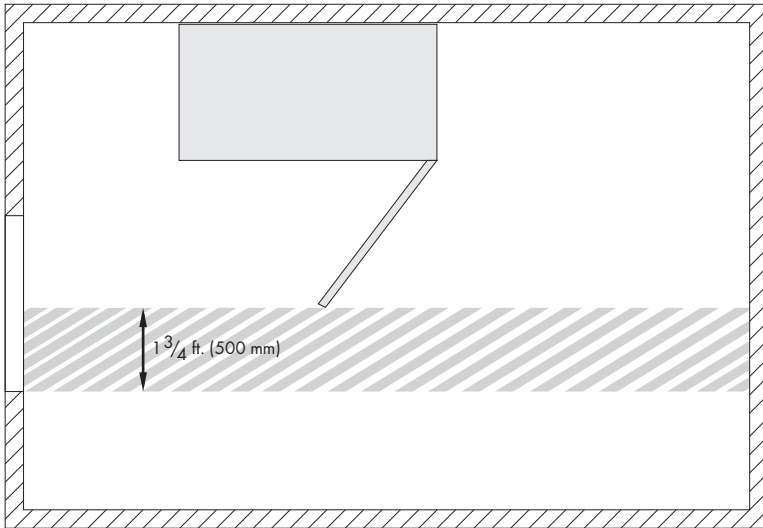

Figure 7: Minimum passage width when the door is open

- Maintain a minimum passage width of  $1\frac{3}{4}$  ft. (500 mm) between the open door of the Multicluster Box and the closest stationary object.
- To allow cable insertion from below, the Multicluster Box must have room for the installation of conduits.

**Cable routes to main cluster:**

The communication cable and control and measuring cables have a limited length and are pre-connected upon delivery of the Multicluster Box.

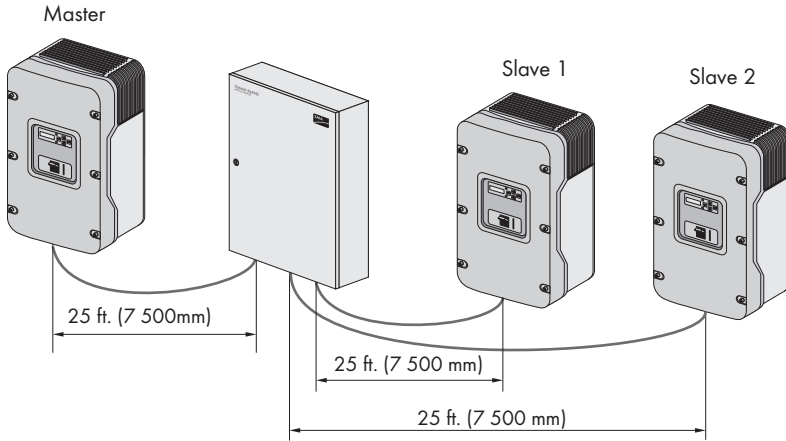

Figure 8: Length of the communication cable and control and measuring cables (example for device arrangement)

- The length of each cable route between the enclosure opening of the Multicluster Box and any one of the 3 off-grid inverters of the main cluster may not exceed 25 ft. (7.5 m).

**Mount the Multicluster Box vertically:**

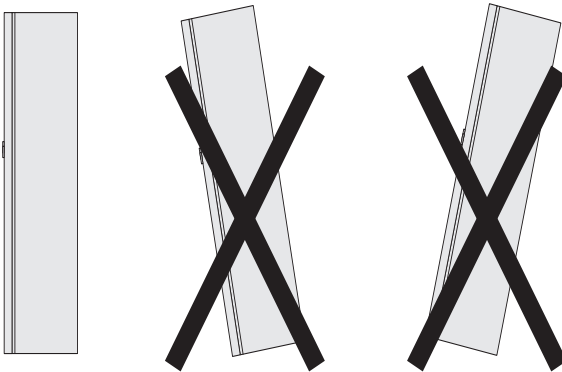

Figure 9: Correct mounting position

- Make sure the installation foundation is horizontal and smooth.

**Dimensions for wall attachment:**

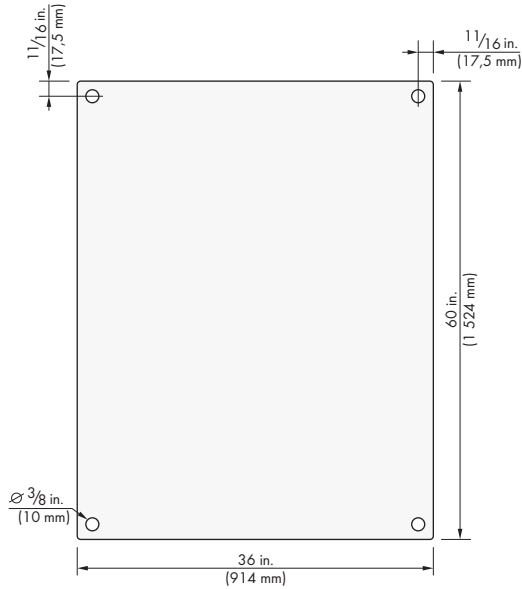

Figure 10: Dimensions of the back panel and dimensions of the drill holes

**Dimensions for ground attachment:**

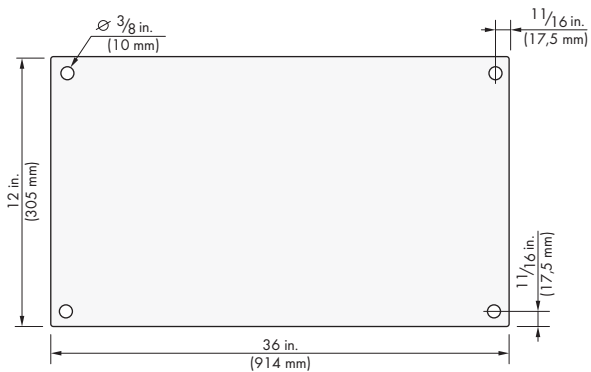

Figure 11: Dimensions of the bottom panel and dimensions of the drill holes

## 5.2 Transporting the Multicluster Box

### **⚠ WARNING**

#### **Heavy weight of the Multicluster Box**

The Multicluster Box may fall down as a result of improper transport.

Death or serious injury from contusions or bone fractures may result.

- The means used to transport or lift the Multicluster Box must be capable of bearing the actual weight of the Multicluster Box (400 lbs. /180 kg).
- Note the center of gravity of the Multicluster Box which is located in the top third of the device.
- When transporting the Multicluster Box, always keep it as close to the ground as possible.
- Make sure the Multicluster Box does not slip or tip over during transport.

#### **Recommended means of transport:**

- Forklift or pallet truck
- Transport belts and transport plates

## 5.3 Installing the Multiclustler Box

### **⚠ WARNING**

#### **Heavy weight of the Multiclustler Box**

The Multiclustler Box may fall down as a result of improper transport.

Death or serious injury from contusions or bone fractures may result.

- The means used to transport or lift the Multiclustler Box must be capable of bearing the actual weight of the device 400 lbs. (180 kg).
- Note the center of gravity of the Multiclustler Box which is located in the top third of the device.
- When transporting the Multiclustler Box, always keep it as close to the ground as possible.
- Make sure the Multiclustler Box does not slip or tip over during transport.

### **NOTICE**

#### **Destruction of the Multiclustler Box due to short circuit**

When performing work on the Multiclustler Box, note that metal fragments or cable remnants may enter the device.

- Use a suitable tool to make holes in the enclosure panels.
- Remove all metal fragments or cable remnants from the Multiclustler Box before commissioning.

#### **Additional required material (not included in the scope of delivery):**

The screws and screw anchors used to install the Multiclustler Box must be suitable given the weight of the device (400 lbs. /180 kg).

- For wall attachment: 4 screws with a diameter of  $\frac{3}{8}$  in. (9 mm)
- For wall attachment: 4 matching screw anchors
- For additional ground attachment: at least 4 screws with a diameter of  $\frac{3}{8}$  in. (9 mm)
- For additional ground attachment: at least 4 matching screw anchors

1. Mark the positions of the 4 drill holes on the wall. Observe the necessary measurements for wall attachment (see 5.1 "Selecting the Installation Location", page 19).
2. Drill the holes in the marked positions with a diameter of  $\frac{3}{8}$  in. (9 mm).



3. Insert matching screw anchors.

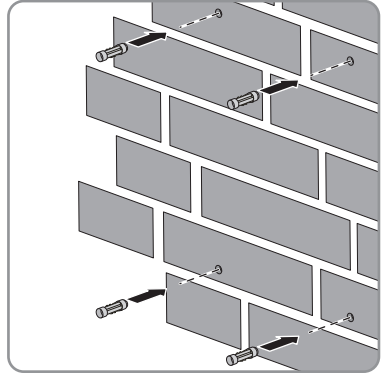

4. Open the door of the Multiclustor Box (see Section 8).
5. Remove the 4 filler-plugs in the back panel of the Multiclustor Box.

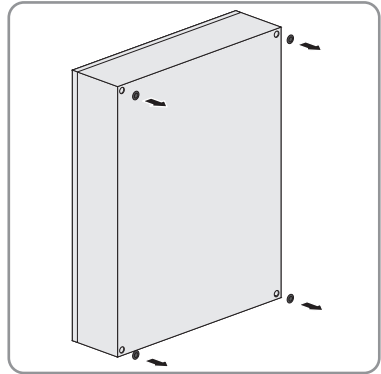

6. For additional ground attachment of the Multiclustor Box, drill mounting holes into the bottom panel:
  - Place the Multiclustor Box on the ground horizontally.
  - Drill at least 4 mounting holes into the bottom panel of the Multiclustor Box. Maintain the required measurements for ground attachment.

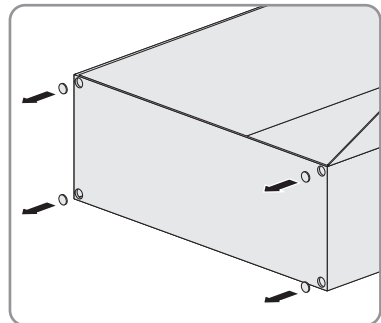

- Set the Multiclustor Box upright and place it on the bottom panel.

7. For additional bottom panel attachment, mark the positions of the drill holes on the ground. Observe the necessary measurements for ground attachment (see Section 5.1 "Selecting the Installation Location", page 19).
8. For additional bottom panel attachment, drill holes in the marked positions with a diameter of  $\frac{3}{8}$  in. (9 mm).
9. Insert matching screw anchors.

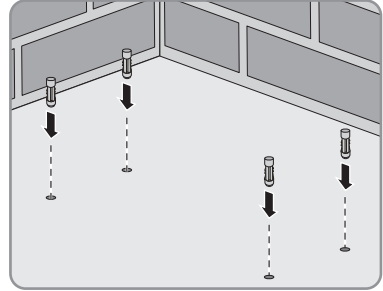

10. Place the Multiclustor Box on the chosen installation location.
11. Align the mounting openings in the Multiclustor Box over the drill holes.

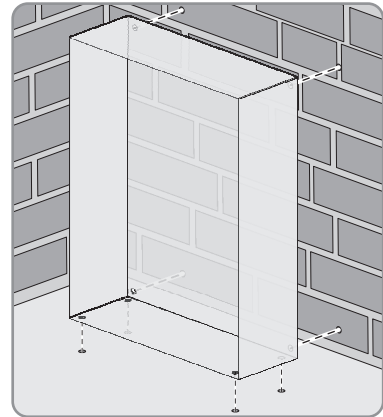

12. Attach the back panel of the Multiclustor Box to the wall with 4 screws.
13. For additional bottom panel attachment, attach the bottom panel to the ground with at least 4 screws.

## 5.4 Mounting the Multicluster Box

### **⚠ WARNING**

#### **Heavy weight of the Multicluster Box**

The Multicluster Box may fall down as a result of improper transport.

Death or serious injury from contusions or bone fractures may result.

- The means used to transport or lift the Multicluster Box must be capable of bearing the actual weight of the Multicluster Box (400 lbs. /180 kg).
- Note the center of gravity of the Multicluster Box which is located in the top third of the device.
- When transporting the Multicluster Box, always keep it as close to the ground as possible.
- Make sure the Multicluster Box does not slip or tip over during transport.

#### **Additional required material (not included in the scope of delivery):**

The screws and screw anchors used to install the Multicluster Box must be suitable given the weight of the device (400 lbs. /180 kg).

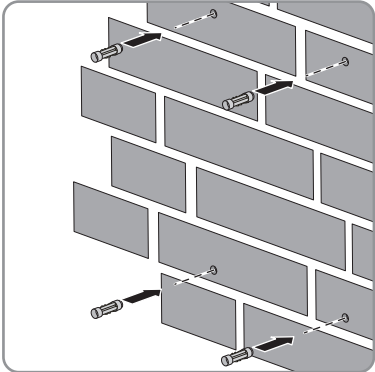
- For wall attachment: 4 screws with a diameter of  $\frac{3}{8}$  in. (9 mm)
  - For wall attachment: 4 matching screw anchors
1. Mark the positions of the 4 drill holes on the wall. Observe the necessary measurements for wall attachment (see 5.1 "Selecting the Installation Location", page 19).
  2. Drill the holes in the marked positions with a diameter of  $\frac{3}{8}$  in. (9 mm).
  3. Insert matching screw anchors.
- 
4. Open the door of the Multicluster Box (see Section 8).

- Remove the 4 filler-plugs in the back panel of the Multiclustor Box.

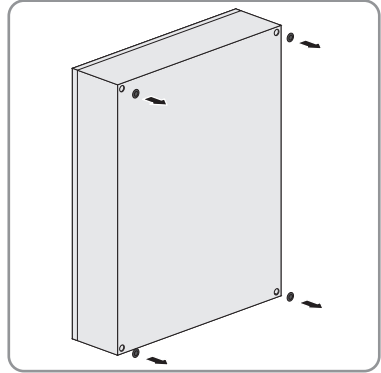

- Insert the screws into the wall. Make sure the screw heads protrude from the wall by at least  $\frac{3}{8}$  in. (10 mm).
- Attach the Multiclustor Box.

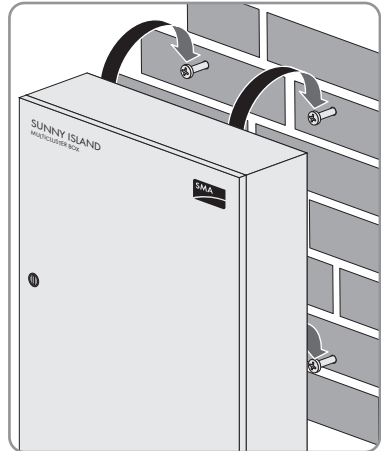

- Tighten the screws in the wall firmly. Use a torque wrench with an attachment suitable for the screw head.

## 6 Electrical Connection

### 6.1 Safety during Electrical Connection

**⚠ DANGER****Danger to life through electric shock**

High voltages in live component parts.

Risk of death or serious injury from touching component parts.

- Disconnect the multicluster system from all voltage sources before carrying out any work on the Multicluster Box (see Section 9 "Disconnecting the Device from Voltage Sources", page 52).

**NOTICE****Humidity and dust intrusion**

Possible damage to the Multicluster Box.

- Protect the Multicluster Box from dust and water whenever it is open.
- Close the door of the Multicluster Box after all work is complete.

**Electrostatic discharge upon contact**

Possible damage to the electronic component parts of the Multicluster Box.

- Ground yourself before touching any component parts.

## 6.2 Overview of the Connection Area

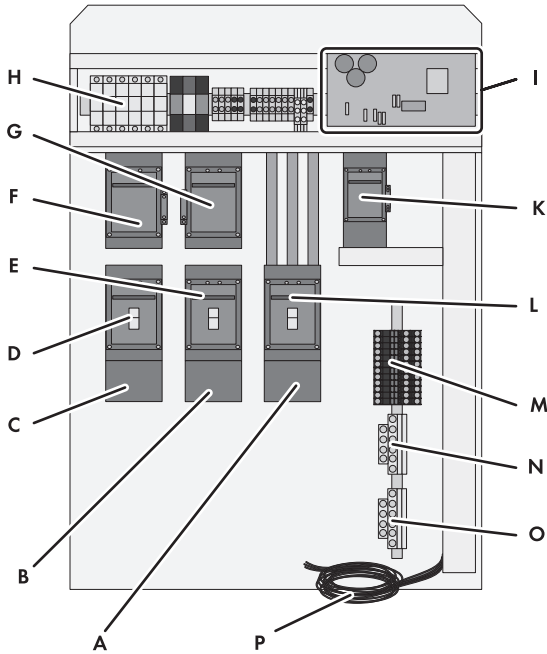

Figure 12: Connections and component parts inside the Multicuster Box

Position	Designation	Explanation
A	"SUNNY BOY INPUT" connection with "L1", "L2", "L3" terminals	For connecting the line conductors of the PV plant
B	"LOAD OUTPUT" connection with "L1", "L2", "L3" terminals	For connecting the line conductors of the loads
C	"GENERATOR INPUT" connection with "L1", "L2", "L3" terminals	For connecting the line conductors of the generator
D	"CB5" fuse-switch-disconnector	For turning on and disconnecting the line conductors of the generator
E	"CB10" fuse-switch-disconnector	For disconnecting and connecting the line conductors of the loads
F	"Q5" contactor	Generator contactor
G	"Q10" contactor	Load contactor
H	"F3" to "F10" fuse holders	With thermal fuses*

<b>Position</b>	<b>Designation</b>	<b>Explanation</b>
I	SIBUCTRL control board assembly	Connection of the 3 control and measuring cables and the communication cable
K	"Q7" contactor	Contactor for off-grid inverters
L	"CB15" fuse-switch-disconnector	For disconnecting and connecting the line conductors of the PV plant
M	"SUNNY ISLAND MASTER CLUSTER", "SUNNY ISLAND EXT. CLUSTER 1", "SUNNY ISLAND EXT. CLUSTER 2" and "SUNNY ISLAND EXT. CLUSTER 3" connections with "L1", "L2", "L3" terminals	For connecting the line conductors of the off-grid inverters
N	"ISOLATED NEUTRAL" connection	For connecting all neutral conductors
O	"EQUIPMENT GROUND (PE)" connection	For connecting all grounding conductors
P	3 control and measuring cables, 1 communication cable	For communication connections of the Multicluster Box with the off-grid inverters of the main cluster

\* "F3" to "F7" fuse holders for 2 A fuse rating, "F8" to "F10" fuse holders for 6 A fuse rating

### 6.3 Inserting the Cables

Insert the cables of the generator, the loads, the PV plant and the Sunny Island as described below.

**Examples for routing cables in the Multicluster Box:**

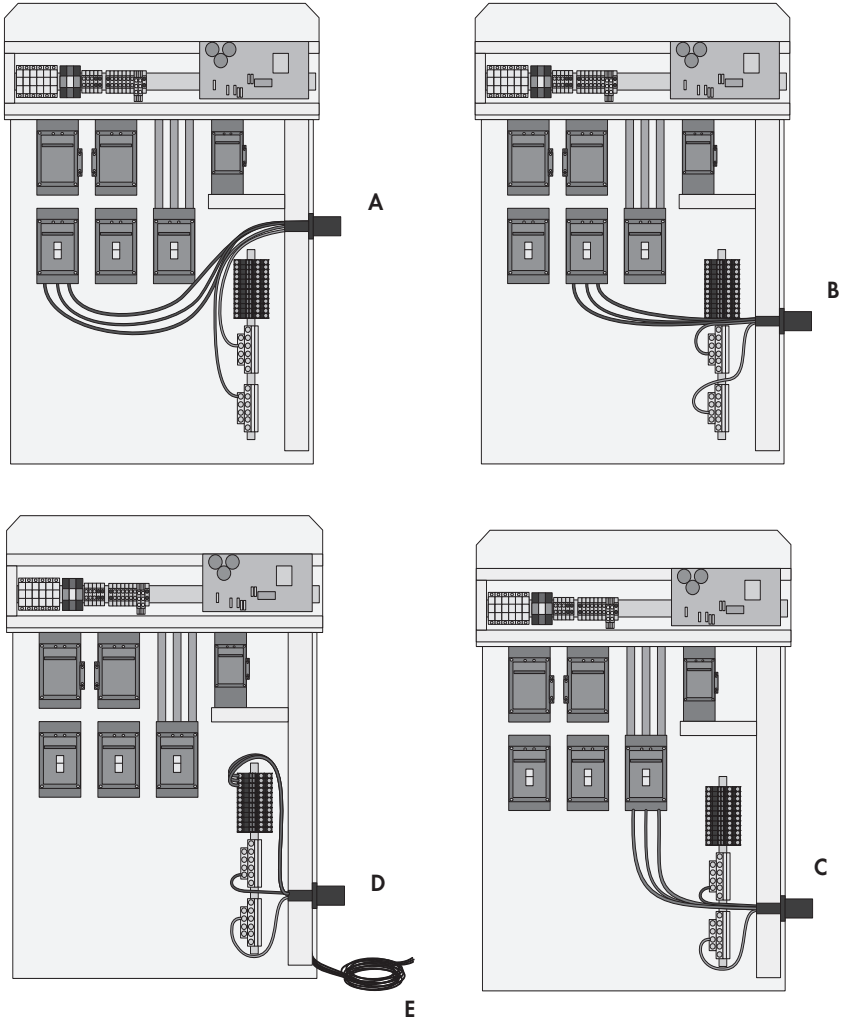

Figure 13: Examples for routing cables in the Multicluster Box with enclosure opening on the right



Position	Designation
A	Enclosure opening for connecting the generator
B	Enclosure opening for connecting the loads
C	Enclosure opening for connecting the PV plant
D	Enclosure opening for connecting the off-grid inverters (based on the example of the main cluster)
E	Enclosure opening for 3 control and measuring cables and 1 communication cable

1. Select the conduit that matches the external diameter of the chosen cable. Observe the *National Electrical Code*®, ANSI/NFPA 70, and all local standards and regulations that may apply.
2. Select the cable insertion opening that matches the diameter of the chosen conduit. With respect to the diameter of the opening, observe the *National Electrical Code*®, ANSI/NFPA 70, and all local standards and regulations that may apply.
3. Select a suitable spot for inserting the cable on the outer panel of the enclosure. Use the left side panel, the right side panel or the bottom panel of the Multicluster Box for this purpose.
4. Open the door of the Multicluster Box (see Section 8).

**NOTICE**

**Destruction of the Multicluster Box due to short circuit**

When performing work on the Multicluster Box, note that metal fragments or cable remnants may enter the device.

- Select a suitable tool to make holes in the enclosure panels.
  - Remove all metal fragments or cable remnants from the Multicluster Box before commissioning.
6. Make a hole with the selected diameter at the selected spot.
  7. Install the conduit as a connection between the Multicluster Box and the component being connected.
  8. Attach the conduit on the inside of the Multicluster Box with a counter nut.
  9. Insert the cable of the component being connected through the conduit into the Multicluster Box.
  10. Measure the cable route for routing the cable or the insulated conductors inside the Multicluster Box. Route the cable or insulated conductors along the inside of the enclosure as far as possible and avoid covering any connections, switches or fuses.
  11. Remove the cable shielding based on the measured route A and leave the insulated conductors open.
  12. Route the insulated conductors inside the Multicluster Box until they connect to the component.
  13. Strip the insulation from the conductors by the length  $C^{13/16}$  in. ...  $1\frac{1}{8}$  in. (20 mm ... 30 mm).

## 6.4 Leading out the Cables

The control and measuring cables and the communication cable are permanently wired in the Multicluster Box. Route these cables out of the Multicluster Box to the master of the main cluster.

1. Select a suitable conduit. Observe the *National Electrical Code*®, ANSI/NFPA 70, and all local standards and regulations that may apply.
2. Select the cable insertion opening that matches the diameter of the chosen conduit. With respect to the diameter of the opening, observe the *National Electrical Code*®, ANSI/NFPA 70, and all local standards and regulations that may apply.
3. Select a suitable spot for inserting the cable on the outer panel of the enclosure.
4. Open the door of the Multicluster Box (see Section 8).

5. **NOTICE**

### **Destruction of the Multicluster Box due to short circuit**

When performing work on the Multicluster Box, note that metal fragments or cable remnants may enter the device.

- Select a suitable tool to make holes in the enclosure panels.
  - Remove all metal fragments or cable remnants from the Multicluster Box before commissioning.
6. Make a hole with the selected diameter at the selected spot.
  7. Install the conduit as a connection between the Multicluster Box and the Sunny Island of the main cluster.
  8. Attach the conduit on the inside of the Multicluster Box with a counter nut.
  9. Via the conduit, route the control and measuring cables and the communication cable of the Multicluster Box to the Sunny Islands of the main cluster.

## 6.5 Connecting the Generator

You can connect a 3-phase generator to the Multicluster Box as an external energy source.

### Cable requirements:

Conductor	Designation	Connectable conductor cross-Section
Line conductor	L1, L2, L3	250 kcmil ... 500 kcmil (127 mm <sup>2</sup> ... 253 mm <sup>2</sup> )
Neutral conductor	N	6 AWG ... 4/0 AWG (14 mm <sup>2</sup> ... 126 mm <sup>2</sup> )
Protective conductor	PE	6 AWG ... 4/0 AWG (14 mm <sup>2</sup> ... 126 mm <sup>2</sup> )

- The conductor cross-Section must be selected based on the nominal power of the generator and remain within the thresholds specified in the table.
- If the generator does not have an output fuse, the cable must be installed in a such way that it is protected against ground faults and short circuits.
- In case of longer cable routes, an additional fuse box must be available in proximity to the generator.

### Required tools:

Use a  $\frac{5}{16}$  in. (8 mm) Allen wrench to tighten the screws on the terminals.

#### **⚠ DANGER**

#### High voltages in the DC cables

Risk of death or serious injury from touching a DC cable.

- Only connect the DC cable from the generator as described in this manual.

1. Insert the cable into the Multicluster Box (see Section 6.3 "Inserting the Cables", page 32).
2. Insert conductor N of the generator into a terminal in the left Section of the "ISOLATED NEUTRAL" connection. Tighten the screw of the terminal (torque: 27 ft.-lbs. (37 Nm)).

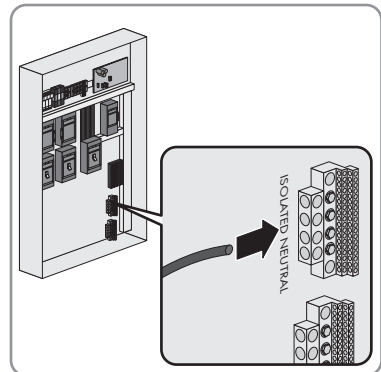

3. Insert conductor PE of the generator into a terminal in the left Section of the "EQUIPMENT GROUND (PE)" connection. Tighten the screw of the terminal (torque: 27 ft.-lbs. (37 Nm)).

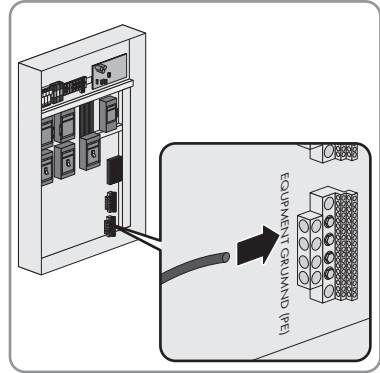

4. With both hands, pull forward the cable cover below the "CB5" fuse-switch-disconnector.
  - ☑ The "L1", "L2", "L3" terminals of the "GENERATOR INPUT" connection are now visible.

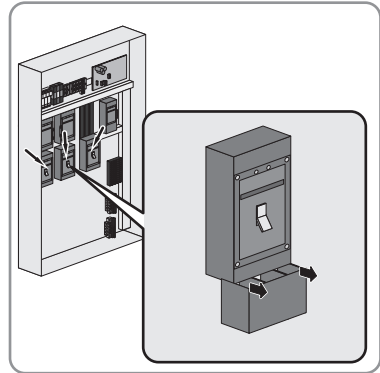

5. Puncture 3 suitable break points in the cable cover and route the line conductors through the openings.

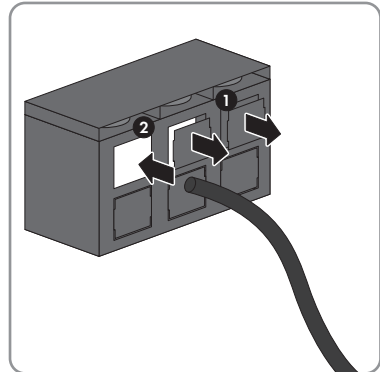

6. Connect the line conductors of the generator to the "GENERATOR INPUT":
  - Insert conductor L1 into terminal "L1" and tighten the screw (torque: 32 ft.-lbs. (43 Nm)).
  - Insert conductor L2 into terminal "L2" and tighten the screw (torque: 32 ft.-lbs. (43 Nm)).
  - Insert conductor L3 into terminal "L3" and tighten the screw (torque: 32 ft.-lbs. (43 Nm)).

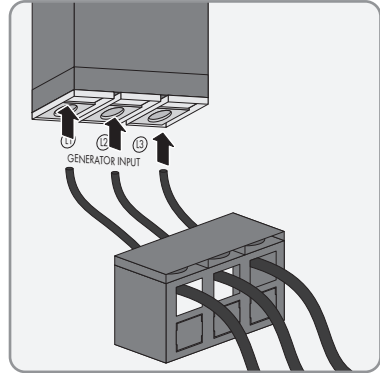

7. Place the cable cover on the lower guide rail of the "CB5" fuse-switch-disconnector and push it back as far as it will go.

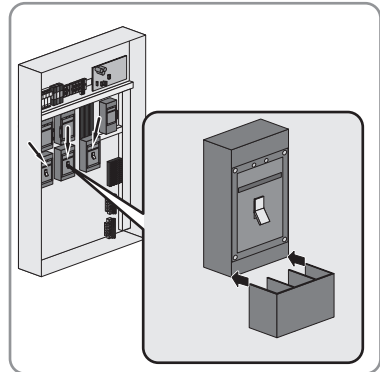

## 6.6 Connecting Loads

The loads in the multicluster system are connected to a separate AC sub-distribution unit. This Section explains how to connect this sub-distribution unit.

### Cable requirements:

Conductor	Designation	Connectable conductor cross-Section
Line conductor	L1, L2, L3	250 kcmil ... 500 kcmil (127 mm <sup>2</sup> ... 253 mm <sup>2</sup> )
Neutral conductor	N	6 AWG ... 4/0 AWG (14 mm <sup>2</sup> ... 126 mm <sup>2</sup> )
Protective conductor	PE	6 AWG ... 4/0 AWG (14 mm <sup>2</sup> ... 126 mm <sup>2</sup> )

**Required tools:**

Use a  $\frac{5}{16}$  in. (8 mm) Allen wrench to tighten the screws on the terminals.

1. Insert the cable into the Multicluster Box (see Section 6.3 "Inserting the Cables", page 32).
2. Insert conductor N of the loads into a terminal in the left Section of the "ISOLATED NEUTRAL" connection. Tighten the screw of the terminal (torque: 27 ft.-lbs. (37 Nm)).

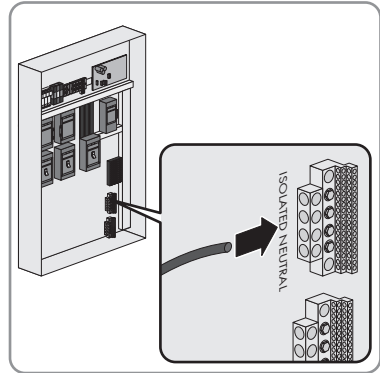

3. Insert conductor PE of the loads into a terminal in the left Section of the "EQUIPMENT GROUND (PE)" connection. Tighten the screw of the terminal (torque: 27 ft.-lbs. (37 Nm)).

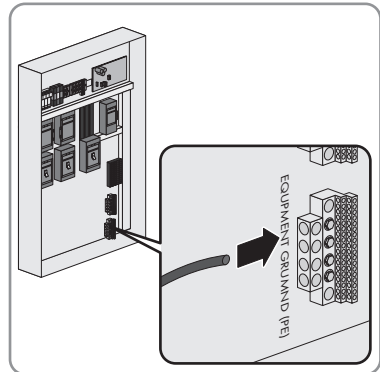

4. With both hands, pull forward the cable cover below the "CB10" fuse-switch-disconnector.
- ☑ The "L1", "L2", "L3" terminals of the "LOAD OUTPUT" connection are now visible.

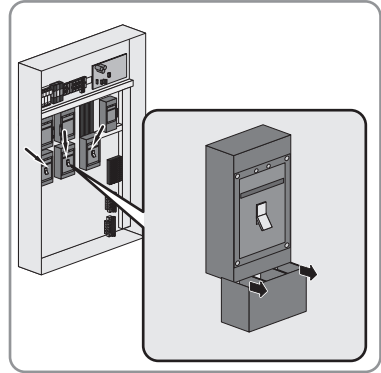

5. Puncture 3 suitable break points in the cable cover and route the line conductors through the openings.

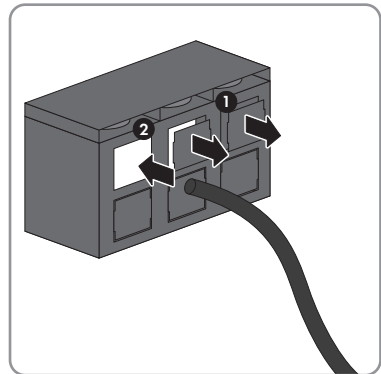

6. Connect the line conductors of the loads to the "LOAD OUTPUT" connection:
- Insert conductor L1 into terminal "L1" and tighten the screw (torque: 32 ft.-lbs. (43 Nm)).
  - Insert conductor L2 into terminal "L2" and tighten the screw (torque: 32 ft.-lbs. (43 Nm)).
  - Insert conductor L3 into terminal "L3" and tighten the screw (torque: 32 ft.-lbs. (43 Nm)).

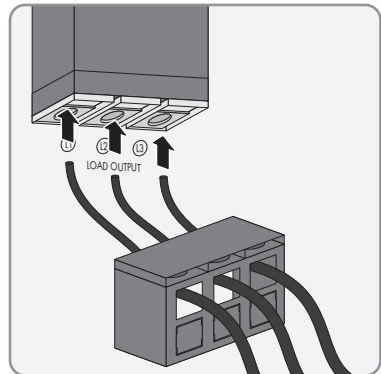

- Place the cable cover on the lower guide rail of the "CB5" fuse-switch-disconnector and push it back as far as it will go.

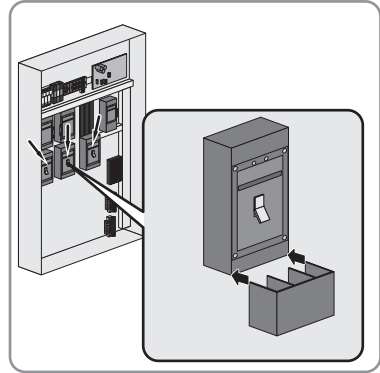

## 6.7 Connecting the PV Plant

### Connecting other energy sources:

Instead of the PV plant, you can also connect other energy sources (e.g. small wind turbine systems) to the Multicluster Box.

### Cable requirements:

Conductor	Designation	Connectable conductor cross-Section
Line conductor	L1, L2, L3	250 kcmil ... 500 kcmil (127 mm <sup>2</sup> ... 253 mm <sup>2</sup> )
Neutral conductor	N	6 AWG ... 4/0 AWG (14 mm <sup>2</sup> ... 126 mm <sup>2</sup> )
Protective conductor	PE	6 AWG ... 4/0 AWG (14 mm <sup>2</sup> ... 126 mm <sup>2</sup> )

### Required tools:

Use a  $\frac{5}{16}$  in. (8 mm) Allen wrench to tighten the screws on the terminals.

### **⚠ DANGER**

#### High voltages on PV modules that are exposed to light

Risk of death due to electric shock from touching a DC conductor.

- During installation, cover the PV modules with opaque material.
- Connect the DC cable from the PV generator exactly as described in this manual.



1. Insert the cable into the Multicluster Box (see Section 6.3).
2. Insert conductor N of the PV plant into a terminal in the left Section of the "ISOLATED NEUTRAL" connection. Tighten the screw of the terminal (torque: 27 ft.-lbs. (37 Nm)).

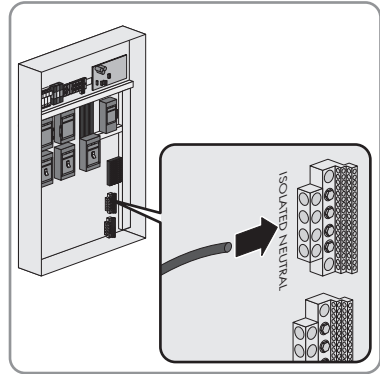

3. Insert conductor PE of the PV plant into a terminal in the left Section of the "EQUIPMENT GROUND (PE)" connection. Tighten the screw of the terminal (torque: 27 ft.-lbs. (37 Nm)).

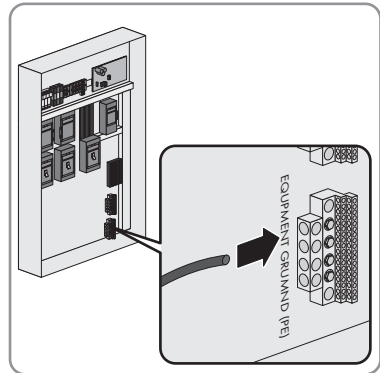

4. With both hands, pull forward the cable cover below the "CB15" fuse-switch-disconnector.
  - ☑ The "L1", "L2", "L3" terminals of the "SUNNY BOY INPUT" connection are now visible.

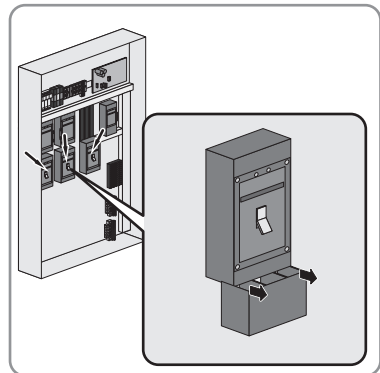

5. Puncture 3 suitable break points in the cable cover and route the line conductors through the opening.

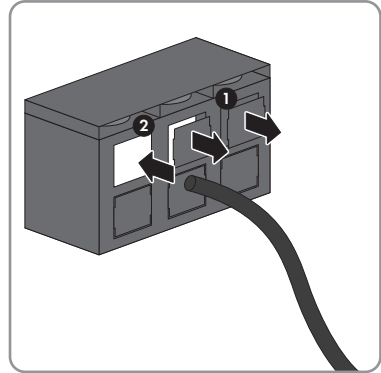

6. Connect the line conductors of the PV plant to the "SUNNY BOY INPUT" connection:

- Insert conductor L1 into terminal "L1" and tighten the screw (torque: 32 ft.-lbs. (43 Nm)).
- Insert conductor L2 into terminal "L2" and tighten the screw (torque: 32 ft.-lbs. (43 Nm)).
- Insert conductor L3 into terminal "L3" and tighten the screw (torque: 32 ft.-lbs. (43 Nm)).

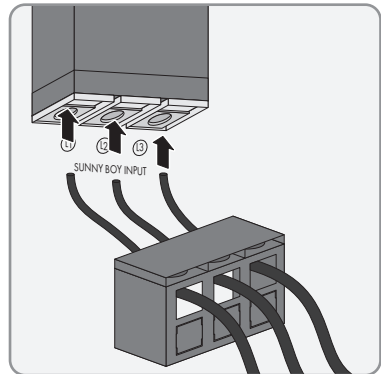

7. Place the cable cover on the lower guide rail of the "CB5" fuse-switch-disconnector and push it back as far as it will go.

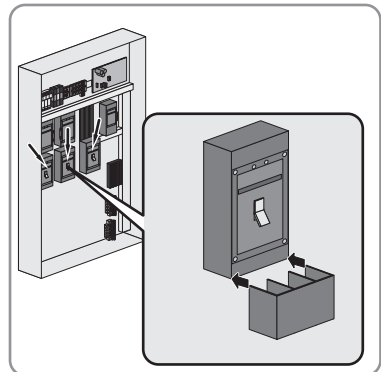

## 6.8 Connecting the Off-Grid Inverter

### Conductor cross-Sections:

Conductor	Designation	Connectable conductor cross-Section
Line conductor	L	4 AWG ... 8 AWG (9 mm <sup>2</sup> ... 21 mm <sup>2</sup> )
Neutral conductor	N	4 AWG ... 8 AWG (9 mm <sup>2</sup> ... 21 mm <sup>2</sup> )
Protective conductor	PE	4 AWG ... 8 AWG (9 mm <sup>2</sup> ... 21 mm <sup>2</sup> )

### Required tools:

Use a flat-head screwdriver to tighten the screws on the terminals (blade width:  $\frac{3}{8}$  in. (9 mm)).

1. Insert the cables into the Multicluster Box (see Section 6.3).
2. Insert conductor N of each off-grid inverter into a terminal in the right Section of the "ISOLATED NEUTRAL" connection. Tighten the screw of the terminal (torque: 45 in.-lbs. (5 Nm)).

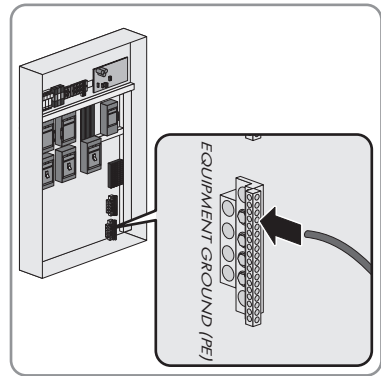

3. Insert conductor PE of each off-grid inverter into a terminal in the right Section of the "EQUIPMENT GROUND (PE)" connection. Tighten the screw of the terminal (torque: 45 in.-lbs. (5 Nm)).

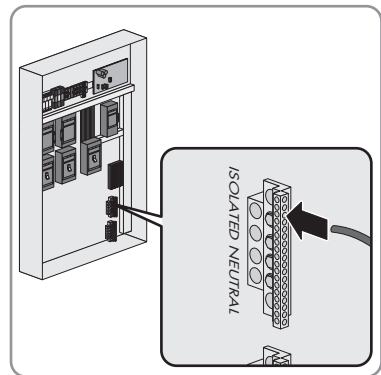

4. Connect the line conductors of the off-grid inverters in the main cluster to the "SUNNY ISLAND Master Cluster" connection:

- Insert conductor L of the master into terminal "L1" and tighten the screw (torque: 45 in.-lbs. (5 Nm)).
- Insert conductor L of slave 1 into terminal "L2" and tighten the screw (torque: 45 in.-lbs. (5 Nm)).
- Insert conductor L of slave 2 into terminal "L3" and tighten the screw (torque: 45 in.-lbs. (5 Nm)).

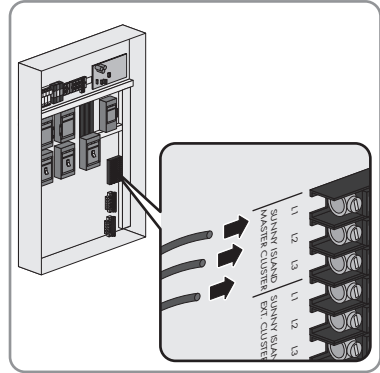

5. Connect the line conductors of the off-grid inverters in extension cluster 1 to the "SUNNY ISLAND EXT. Cluster 1" connection:

- Insert conductor L of the master into terminal "L1" and tighten the screw (torque: 45 in.-lbs. (5 Nm)).
- Insert conductor L of slave 1 into terminal "L2" and tighten the screw (torque: 45 in.-lbs. (5 Nm)).
- Insert conductor L of slave 2 into terminal "L3" and tighten the screw (torque: 45 in.-lbs. (5 Nm)).

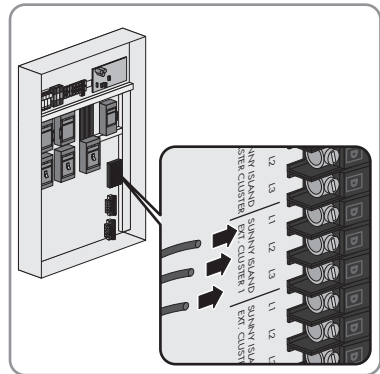

6. To connect the line conductors of the off-grid inverters in extension cluster 2 to the "SUNNY ISLAND EXT. Cluster 2" connection, perform the following steps:

- Insert conductor L of the master into terminal "L1" and tighten the screw (torque: 45 in.-lbs. (5 Nm)).
- Insert conductor L of slave 1 into terminal "L2" and tighten the screw (torque: 45 in.-lbs. (5 Nm)).
- Insert conductor L of slave 2 into terminal "L3" and tighten the screw (torque: 45 in.-lbs. (5 Nm)).

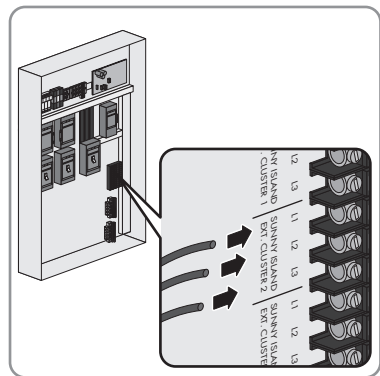

7. To connect the line conductors of the off-grid inverters in extension cluster 3 to the "SUNNY ISLAND EXT. Cluster 3" connection, perform the following steps:

- Insert conductor L of the master into terminal "L1" and tighten the screw (torque: 45 in.-lbs. (5 Nm)).
- Insert conductor L of slave 1 into terminal "L2" and tighten the screw (torque: 45 in.-lbs. (5 Nm)).
- Insert conductor L of slave 2 into terminal "L3" and tighten the screw (torque: 45 in.-lbs. (5 Nm)).

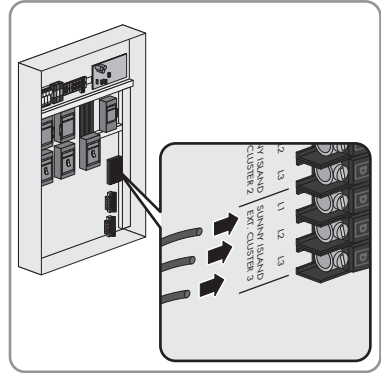

## 6.9 Grounding the Multicluster System

The neutral conductors inside the Multicluster Box are not connected to PE by default. To ensure safe operation of the Multicluster system, you must take the following measure prior to commissioning:

- Ground the Multicluster system outside the Multicluster Box on either the generator side or the load side. To do so, connect the neutral conductor to PE. Observe the *National Electrical Code*<sup>®</sup>, ANSI/NFPA 70, and all local standards and regulations that may apply.

## 6.10 Connecting the Control and Measuring Cables

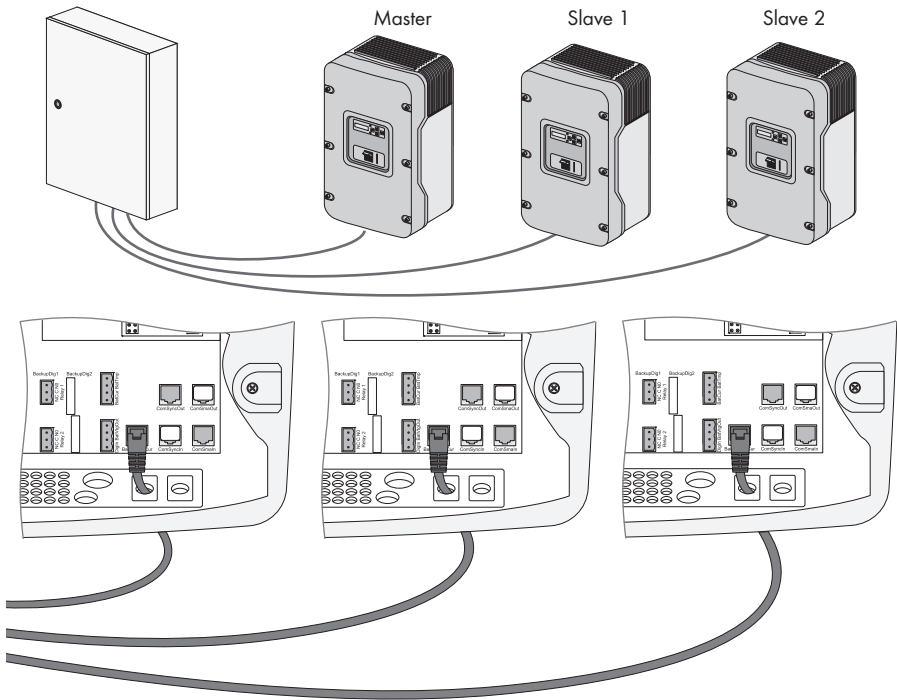
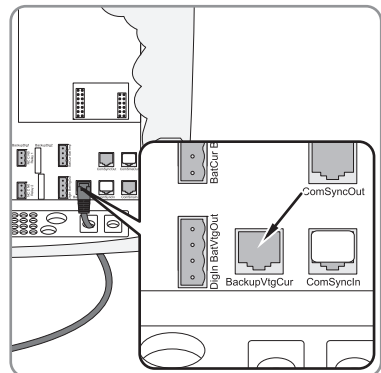

Figure 14: Connecting the control and measuring cables of the Multicluster Box to the off-grid inverters in the main cluster

1. Lead the 3 red control and measuring cables out of the Multicluster Box (see Section 6.4).
2. Insert the control and measuring cable "Master BackupVtgCur" on the master of the main cluster into the RJ45 jack "BackupVtgCur".
3. Insert the control and measuring cable "Slave 1 BackupVtgCur" on slave 1 of the main cluster into the RJ45 jack "BackupVtgCur".
4. Insert the control and measuring cable "Slave2 BackupVtgCur" on slave 2 of the main cluster into the RJ45 jack "BackupVtgCur".



### 6.11 Connecting the Communication Cable

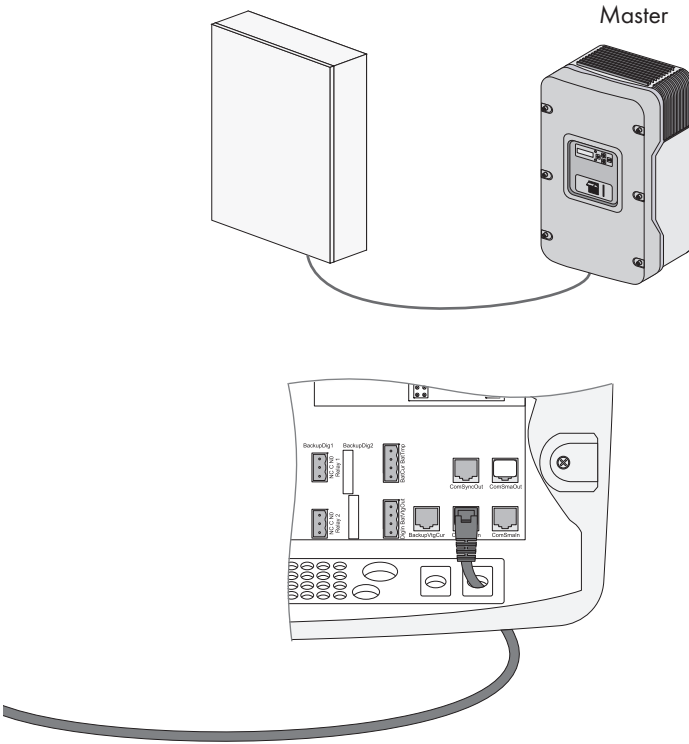
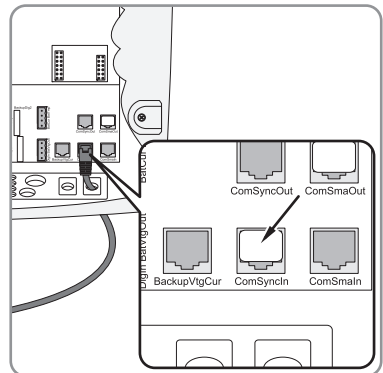

Figure 15: Connecting the communication cable of the Multicuster Box on the master of the main cluster

1. Lead the black communication cable out of the Multicuster Box (see Section 6.4).
2. Insert the communication cable "SI Master ComSyncOut" on the master of the main cluster into the RJ45 jack "ComSyncln".



## 7 Commissioning

- The Multicluster Box is installed properly.
- All cables are installed in the conduits.
- All conduits are screwed in place inside the Multicluster Box.
- All cables are retained in the conduits.
- All cables are correctly and completely connected.
- The Multicluster system is grounded.

### **⚠ DANGER**

#### **Danger to life through electric shock**

High voltages in live component parts.

Risk of death or serious injury from touching component parts.

- Disconnect the multicluster system from all voltage sources before carrying out any work on the Multicluster Box (see Section 9 "Disconnecting the Device from Voltage Sources", page 52).

If there is no electrical connection between the door and the cabinet body of the Multicluster Box, then voltage may be present in the door.

Risk of death or serious injury from touching the door.

- Make sure the door of the Multicluster Box is always connected to the "⊕" connection on the top right-hand side of the cabinet. The pre-assembled grounding cable must remain connected at all times.

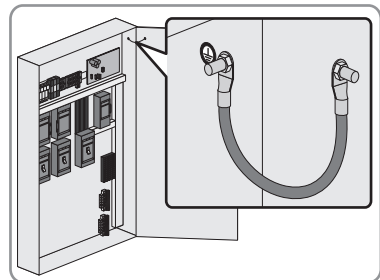

### **⚠ CAUTION**

#### **Danger of fire due to incorrectly dimensioned fuse**

If a fuse is incorrectly dimensioned, electrical connections may overheat and cause fires. Risk of injury due to fire.

- Always use thermal fuses that match the rating specified on the "F3" to "F10" fuse holders.
- Always replace defective fuses with fuses of the same type and with the same rating.

1. Make sure the "F3" to "F10" fuse holders contain thermal fuses with the specified rating.  
Tip: The specified rating is indicated under the fuse holder.



- Close the "F3" to "F10" fuse holders by pushing the levers of the fuse holders up until they snap into place.

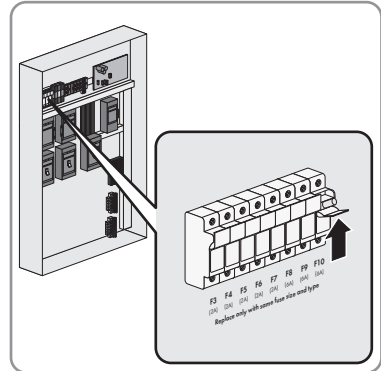

- Set the switch levers on the "CB5", "CB10" and "CB15" fuse-switch-disconnectors to **ON**.

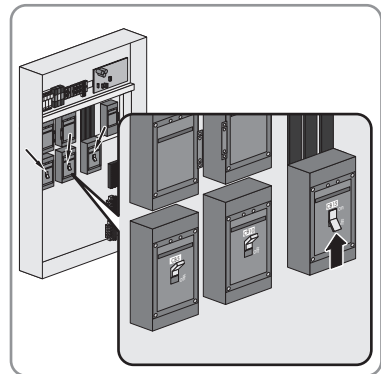

- Close the door of the Multiclustor Box (see Section 8).
- Start up the multiclustor system (see manual for the off-grid inverter).

## 8 Opening and Closing the Multicluster Box

### **⚠ DANGER**

#### **Danger to life through electric shock**

High voltages in live component parts.

Risk of death or serious injury from touching component parts.

- Disconnect the multicluster system from all voltage sources before carrying out any work on the Multicluster Box (see Section 9 "Disconnecting the Device from Voltage Sources", page 52).

If there is no electrical connection between the door and the cabinet body of the Multicluster Box, then voltage may be present in the door.

Risk of death or serious injury from touching the door.

- Make sure the door of the Multicluster Box is always connected to the "⊕" connection on the top right-hand side of the cabinet. The pre-assembled grounding cable must remain connected at all times.

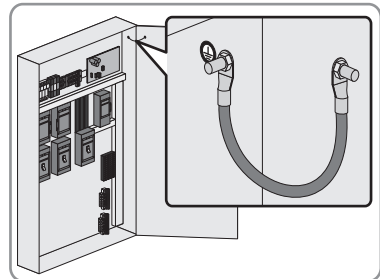

#### **Required tools:**

- Flat-head screwdriver (blade length:  $\frac{3}{8}$  in. (10 mm))

- To open the door of the Multicluster Box, insert the flat-head screwdriver all the way into the opening of the door locking mechanism and rotate counter clockwise by 45°.

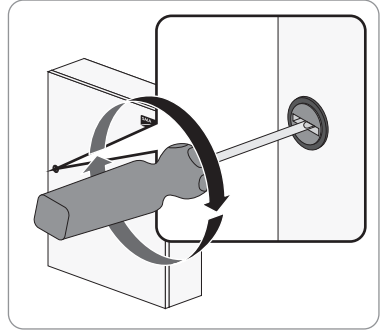

- To close the door of the Multicluster Box, insert the flat-head screwdriver all the way into the opening of the door locking mechanism and rotate clockwise by 45°.

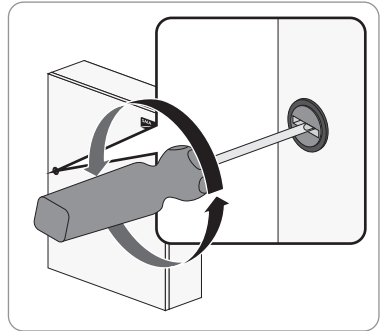

## 9 Disconnecting the Device from Voltage Sources

### **⚠ DANGER**

#### **Danger to life through electric shock**

High voltages in live component parts.

Risk of death or serious injury from touching component parts.

- Disconnect the multicluster system from all voltage sources as described in this Section before carrying out any work on the Multicluster Box.

1. Switch off all loads.
2. Switch off the master of the main cluster.
3. Disconnect all off-grid inverters and secure against unintentional reconnection (see technical descriptions for the off-grid inverters).
4. Disconnect the PV main distributor and secure against unintentional reconnection.
5. Shut down the generator and secure against unintentional reconnection.
6. Set the switch lever on the "CB5", "CB10" and "CB15" fuse-switch-disconnectors of the Multicluster Box to OFF.

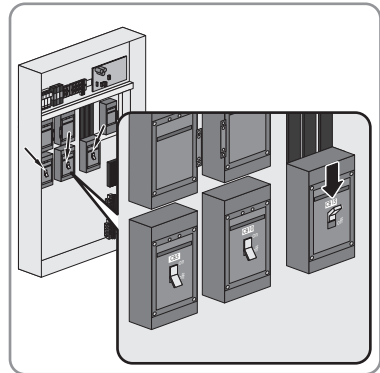

7. Open the "F3" to "F10" fuse holders of the Multicluster Box and secure against unintentional reconnection.

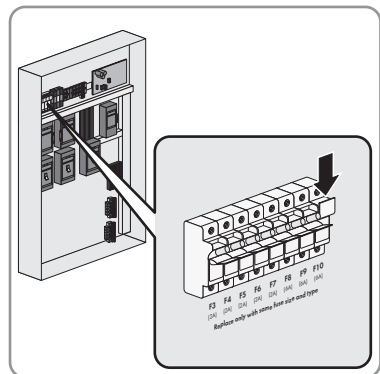

8. Make sure no voltage or current is present.
9. Cover or shield any adjacent live components.

## 10 Maintenance

Maintenance work	Recommended maintenance interval
<p>Make sure the inside of the Multicluster Box is clean and dry.</p> <ul style="list-style-type: none"> <li>• If the inside of the Multicluster Box is dirty, clean the device.</li> <li>• If the inside of the Multicluster Box is moist or water has accumulated on the bottom, dry out the device.</li> </ul>	12 months
<p>Make sure all connections are firmly in place.</p> <ul style="list-style-type: none"> <li>• Tighten any loose screws on the terminals. When doing so, observe the specified torque (see Section 6 "Electrical Connection", page 29).</li> </ul>	12 months
<p>Check whether the conductors, terminals or fuse elements are discolored or have changed.</p> <ul style="list-style-type: none"> <li>• If a fuse element is discolored or has changed, replace it.</li> <li>• If a cable or insulated conductor to a component of the multicluster system is discolored or has changed (e.g. to the off-grid inverter), replace the cable or insulated conductor (see Section 6 "Electrical Connection", page 29).</li> <li>• If a terminal or insulated conductor in the Multicluster Box is discolored or has changed, contact the SMA Service Line (see Section 14 "Contact", page 61).</li> </ul>	12 months

- Perform regular maintenance on the Multicluster Box. Note that the length of maintenance interval is influenced by the ambient conditions at the installation site.
- The Multicluster Box must be maintained more frequently if it is installed in environments with severe dust pollution.

# 11 Replacing Thermal Fuses

## **⚠ DANGER**

### **Danger to life through electric shock**

High voltages in live component parts.

Risk of death or serious injury from touching component parts.

- Disconnect the multicaster system from all voltage sources before carrying out any work on the Multicaster Box (see Section 9 "Disconnecting the Device from Voltage Sources", page 52).

1. Open the fuse holder by pushing the lever of the fuse holder forward.

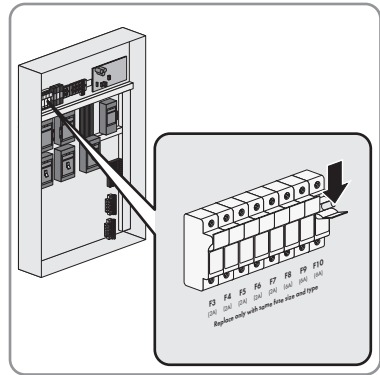

- Remove defective thermal fuses from the fuse holders.

**NOTICE**

**Danger of fire due to incorrectly dimensioned fuse**

If a fuse is incorrectly dimensioned, electrical connections may overheat and cause fires. Risk of injury due to fire.

- Insert new thermal fuses of the same type and with the same rating into the fuse holders.

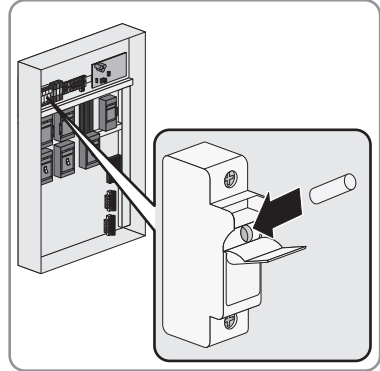

- Close the fuse holder by pushing the lever of the fuse holder up until the holder snaps into place.

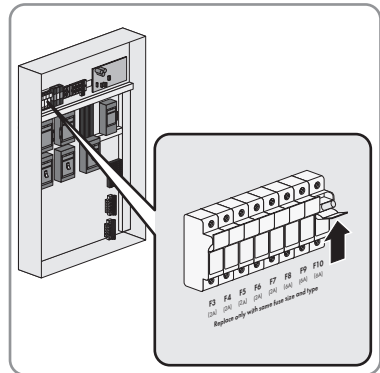

## 12 Decommissioning

### 12.1 Dismantling the Multicluster Box

**⚠ DANGER****Danger to life through electric shock**

High voltages in live component parts.

Risk of death or serious injury from touching component parts.

- Disconnect the multicluster system from all voltage sources before carrying out any work on the Multicluster Box (see Section 9 "Disconnecting the Device from Voltage Sources", page 52).

1. Open the door of the Multicluster Box (see Section 8).
2. Remove all cables from the Multicluster Box.
3. Disconnect all conduits from the Multicluster Box.
4. Remove the fastening screws from the back panel of the Multicluster Box and, if necessary, from the bottom panel as well.
5. Close all enclosure openings.
6. Use the door handle to close the Multicluster Box (see Section 8).
7. Transport the Multicluster Box using a suitable means of transport (see Section 5.2 "Transporting the Multicluster Box", page 23).

### 12.2 Storing the Multicluster Box

- Store the Multicluster Box in a dry place where the ambient temperature is between  $-13^{\circ}\text{F}$  ( $-25^{\circ}\text{C}$ ) and  $+140^{\circ}\text{F}$  ( $+60^{\circ}\text{C}$ ) at all times.
- Make sure that no foreign bodies are allowed to enter the Multicluster Box.

### 12.3 Disposing of the Multicluster Box

- Dispose of the Multicluster Box in accordance with all applicable disposal regulations for electronic waste.



## 13 Technical Data

### General Data

Number of phases	3
Nominal voltage per phase	120 V
Nominal voltage over 3 phases	208 V
Voltage range per phase	105 V ... 132 V
Voltage range over 3 phases	181 V ... 229 V
Nominal frequency	60 Hz
Frequency range	55 Hz ... 65 Hz
Width x height x depth	36 in. x 60 in. x 12 in. (914 mm x 1 524 mm x 305 mm)
Weight	400 lbs. (180 kg)
Permitted grounding system	No power distribution grid, otherwise all grid types
Certification	UL 508A
Maximum installation altitude	6 560 ft. (2 000 m)
Degree of protection	NEMA 12
Operating temperature	- 13°F ... 122°F ( - 25°C ... 60°C)

### Off-Grid Inverter Connection

Number of phases	3
Maximum number of off-grid inverters	12
Frequency	60 Hz
Rated voltage for 1 phase	120 V
Rated voltage for 3 phases	208 V
AC input current	12 x 42 A
Rated input power at 77°F (25°C)	60 kW
AC output current per off-grid inverter	56 A
Rated output power at 77°F (25°C)	80 kW
Short-circuit current capability	10 kA
Connection type	Bi-directional

## PV Plant Connection

Number of phases	3
Frequency	60 Hz
Rated voltage for 1 phase	120 V
Rated voltage for 3 phases	208 V
AC input current	3 x 300 A
Rated input power at 77°F (25°C)	108 kW
Short-circuit current capability	16 kA
Connection type	Input

## Load Connection

Number of phases	3
Frequency	60 Hz
Rated voltage for 1 phase	120 V
Rated voltage for 3 phases	208 V
AC input current	3 x 300 A
Rated input power at 77°F (25°C)	108 kW
Short-circuit current capability	16 kA
Connection type	Output

## Generator Connection

Number of phases	3
Frequency	60 Hz
Rated voltage for 1 phase	120 V
Rated voltage for 3 phases	208 V
AC input current	3 x 300 A
Rated input power at 77°F (25°C)	108 kW
Short-circuit current capability	16 kA
Connection type	Input

## Conductor Cross-Sections of Terminals

Line conductor of the generator	250 kcmil ... 500 kcmil (127 mm <sup>2</sup> ... 253 mm <sup>2</sup> )
Neutral conductor of the generator	6 AWG ... 4/0 AWG (14 mm <sup>2</sup> ... 126 mm <sup>2</sup> )
Protective conductor of the generator	6 AWG ... 4/0 AWG (14 mm <sup>2</sup> ... 126 mm <sup>2</sup> )
Line conductor of the loads	250 kcmil ... 500 kcmil (127 mm <sup>2</sup> ... 253 mm <sup>2</sup> )
Neutral conductor of the loads	6 AWG ... 4/0 AWG (14 mm <sup>2</sup> ... 126 mm <sup>2</sup> )
Protective conductor of the loads	6 AWG ... 4/0 AWG (14 mm <sup>2</sup> ... 126 mm <sup>2</sup> )
Line conductor of the PV plant	250 kcmil ... 500 kcmil (127 mm <sup>2</sup> ... 253 mm <sup>2</sup> )
Neutral conductor of the PV plant	6 AWG ... 4/0 AWG (14 mm <sup>2</sup> ... 126 mm <sup>2</sup> )
Protective conductor of the PV plant	6 AWG ... 4/0 AWG (14 mm <sup>2</sup> ... 126 mm <sup>2</sup> )
Line conductor of an off-grid inverter	4 AWG ... 8 AWG (9 mm <sup>2</sup> ... 21 mm <sup>2</sup> )
Neutral conductor of an off-grid inverter	4 AWG ... 8 AWG (9 mm <sup>2</sup> ... 21 mm <sup>2</sup> )
Protective conductor of an off-grid inverter	4 AWG ... 8 AWG (9 mm <sup>2</sup> ... 21 mm <sup>2</sup> )

## Screws on the Terminals

Screw type on connection for generator	Hexagon socket
Screw head diameter on connection for generator	$\frac{5}{16}$ in. (8 mm)
Screw type on connection for loads	Hexagon socket
Screw head diameter on connection for loads	$\frac{5}{16}$ in. (8 mm)
Screw type on connection for PV plant	Hexagon socket
Screw head diameter on connection for PV plant	$\frac{5}{16}$ in. (8 mm)
Screw type on connection for off-grid inverters	Slotted screw
Screw head width on connection for off-grid inverters	$\frac{3}{8}$ in. (9 mm)

## Torques of the Screws on the Terminals

For the line conductors of the generator	32 ft.-lbs. (43 Nm)
For the neutral conductor of the generator	27 ft.-lbs. (37 Nm)
For the protective conductor of the generator	27 ft.-lbs. (37 Nm)
For the line conductors of the loads	32 ft.-lbs. (43 Nm)
For the neutral conductor of the loads	27 ft.-lbs. (37 Nm)
For the protective conductor of the loads	27 ft.-lbs. (37 Nm)
For the line conductors of the PV plant	32 ft.-lbs. (43 Nm)
For the neutral conductor of the PV plant	27 ft.-lbs. (37 Nm)
For the protective conductor of the PV plant	27 ft.-lbs. (37 Nm)
For the line conductor of an off-grid inverter	45 ft.-lbs. (5 Nm)
For the neutral conductor of an off-grid inverter	45 ft.-lbs. (5 Nm)
For the protective conductor of an off-grid inverter	45 ft.-lbs. (5 Nm)

## Thermal Fuses

Rating of thermal fuse "F3" ... "F7"	2 A
Rating of thermal fuse "F8" ... "F10"	6 A

## 14 Contact

If you encounter technical problems with our products, contact the SMA Service Line. We need the following data in order to provide you with the necessary assistance:

- Type of Multicluster Box
- Serial number of Multicluster Box
- Type and number of connected off-grid inverters
- Type and number of connected PV inverters
- Type and number of connected loads
- If a generator is connected:
  - Type
  - Power
  - Maximum current

### **SMA Solar Technology America, LLC**

6020 West Oaks Blvd, Ste 300

Rocklin, CA 95765

Tel. +1 916 625 0870

Tel. +1 877-MY SMA TECH

Tel. +1 877 697 6283 (Toll free, available for USA, Canada and Puerto Rico)

Fax +1 916 625 0871

Service@SMA-America.com

www.SMA-America.com





**SMA Solar Technology**

**www.SMA-Solar.com**

**SMA America, LLC**

[www.SMA-America.com](http://www.SMA-America.com)

